



SMXir Keypad (3/4) door /Display with Remote Control

Cruisair offers two different SMX microprocessor control systems for use with tempered water (TW) air conditioning systems. SMX II offers the standard operational and safety features required for most systems. SMX Net adds networking capability and other special features that make it unique in the industry. The SMX II or SMX Net power/logic module is sold separately and wires to the air handler junction box with the supplied 3 ft. (.9m) wire harness. Either system can be retrofitted in the field to replace an electromechanical switch assembly. The SMXir keypad/display and optional SMXir remote is used on both SMX II and SMX Net systems.

Normal operation consists of simply turning the system on by pressing the RUN button and adjusting the desired cabin temperature setpoint. A change-over thermostat on the air handler monitors the water temperature to tell the SMX control whether the system is in cooling or heating. Fan speed is automatically controlled (fan speed decreases as room temperature approaches setpoint), or the fan speed can be set manually. Either system will control air handlers with auxiliary electric heat.

Many of the factory settings can be changed to allow the user to fine-tune the system to best match the boat and personal preferences. (See the chart on the back for a list of programmable functions.)

A nonvolatile memory retains current operation mode and all programmable settings when power is turned off or lost, such as when changing from generator to dock power.

In addition to all the standard SMX function listed above, the SMX Net system allows multiple units to be networked together for central control.

Each unit in the network has a unique ID number, and any unit can be accessed and controlled from any other control in the network. SMX Net also permits one unit to be “slaved” to another so that only one keypad can be used to control multiple units in a large cabin. Additional SMX Net features include outside temperature display, 2-speed fan control, and an optional SMX Net Convenience Panel, from which the entire network can be easily controlled with a single keystroke to go into one of four programmed modes.

SMXir Display

The SMXir keypad/display has an attractive, compact housing with easy surface-mount installation. A large, easy-to-read LED display shows cabin temperature, setpoint, programming prompts, and fault code warnings, and small LED's and backlit text indicate system status. Under a decorative hinged door is the familiar SMX 10-button arrangement with clearly labeled keys for single-keystroke operation. An optional infrared remote control is available that allows system adjustments to be made remotely.

The SMXir keypad/display can be used with either SMX II or SMX Net microprocessor control systems. A complete system consists of a SMX II or SMX Power/Logic module (model PLTX-HV for SMX II, model NPLTX for SMX Net), an SMXir keypad/display, a CXP connecting cable, and a TSEP temperature sensor. Additional components will be needed to network multiple SMX Net units, including; CNP network cables, one TSEP temperature sensor for outside temperature, and the optional SMXir Convenience Panel (the convenience panel kit includes an SMXir keypad/display connected to a SMXir Convenience panel with a 2ft (0.61 m) ribbon cable: CCP2. A 4ft (2.1 m) ribbon cable: CCP4 is also available. The 4ft cable must be purchased separately.).

Specifically designed for the marine environment, the SMXir features a plastic housing, sealed membrane keypad, and electronics with anticorrosion coating. Housings are available in black or white, and with either a 3/4 or full coverage door.

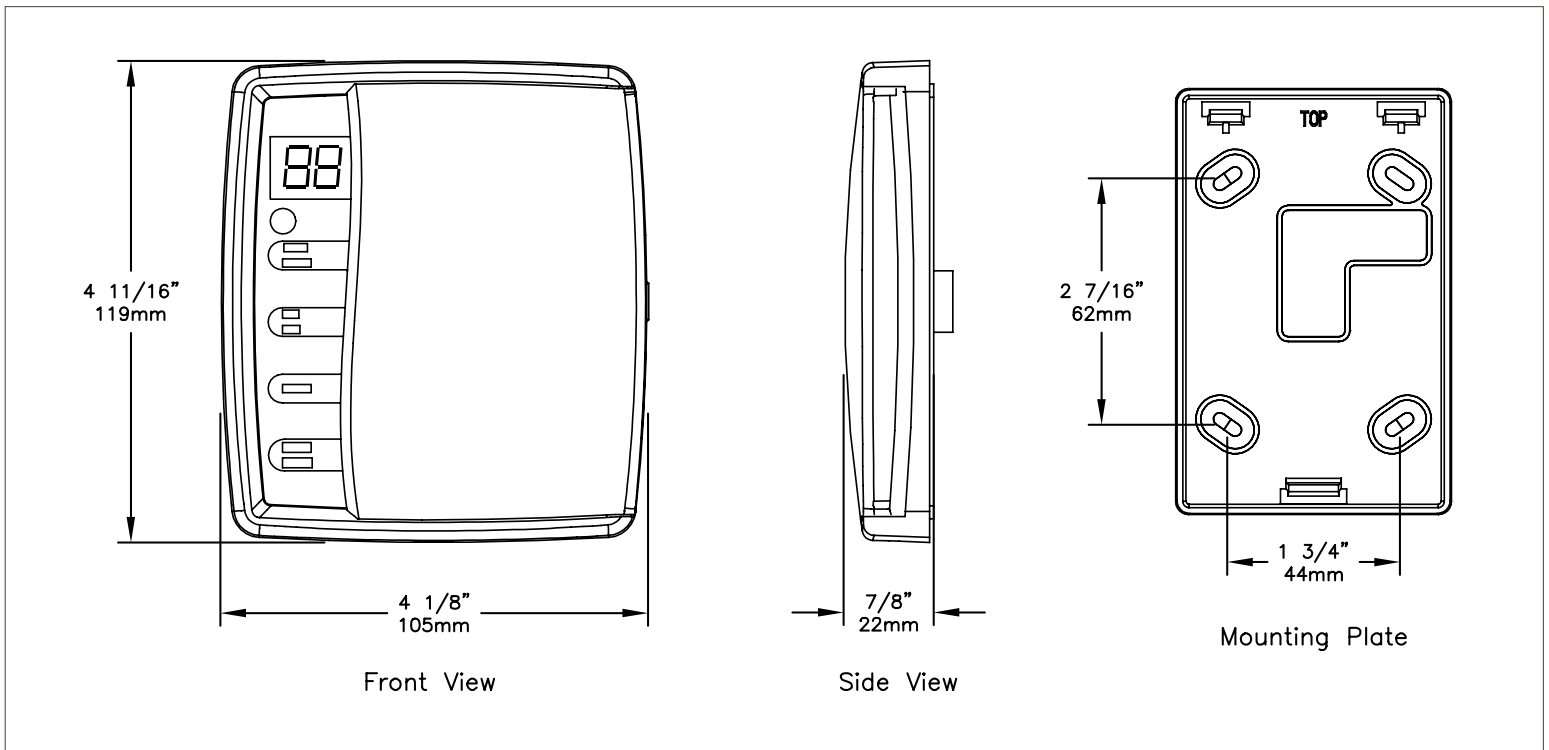

Features

- Works with SMXir Keypad/Display
- Works with SMXir Remote
- Automatic/Manual Fan Speed Control
- Optional 2-Speed Fan (SMX Net only)
- Inside Temperature Display
- Outside Temperature Display (SMX Net only)
- Auxiliary Heat Control
- Dehumidification (absent) Program
- Nonvolatile Memory
- Fault Display
- Software Update Capability (SMX Net only)
- Remote System Control (SMX Net only)
- Slaving Capability (SMX Net only)
- Optional Convenience Panel (SMX Net only)
- Brightness Control

Programmable Functions

- Factory Memory Reset
- Fahrenheit/Celsius Display
- High Fan Speed Adjustment
- Low Fan Speed Adjustment
- Bypass Valve Differential
- Fan Response Differential
- Continuous/Intermittent Fan
- Temperature Calibration
- Dehumidification Cycle

Dometic Corporation

Environmental Systems

P.O. Box 15299 • Richmond, VA 23227-0699 USA • Phone: 804-746-1313 • Facsimile: 804-746-7248

2000 N. Andrews Ave. Ext. • Pompano Beach, FL 33069-1497 USA • Phone: 954-973-2477 • Facsimile: 954-979-4414

Fleets Industrial Estate • 26 Willis Way • Poole, Dorset BH15 3SU, England • Phone: +44(0)870 3306101 • Facsimile: +44(0)870 3306102

Email: sales@cruisair.com • Website: www.cruisair.com

Revised: 09-28-04 L-2089